

Physics 122 – Fundamentals of Physics II

Fall 2020

Lecturer: **Dr. Heidarian**

Email: nheidari@umd.edu

PLEASE READ CAREFULLY!

- The lecture portion of this class will be provided as recorded lectures (Asynchronous). Please plan on being available during all scheduled class times for this course. All assignments will be given during normal class time.
- **Recommended Textbook:** “College Physics: A Strategic Approach” by Knight, Jones and Field, published by Addison-Wesley / Pearson. This textbook is recommended for the course. You can also use other editions of the book or any other General Physics book you can find.
- **Website:** The class schedule and any class related activity (grades, assignments etc.) will be posted on ELMS. <http://elms.umd.edu>
- It is your responsibility to check ELMS, and all announcements, due dates, exam dates carefully.
- **Office Hours:** Will be announced soon
- All labs and Homework will be carried out with Expert TA. You need to purchase the access keys and register for both ExpertTA lab and ExpertTA homework and **they need to be purchased separately.**
- The registration link for **homework** is the following

<http://goeta.link/USH22MD-B48A7B-215>

*** Please see the lab section of the syllabus where you can find the the lab portion registration link based on your section.**

- Please read the syllabus carefully and if you have any questions regarding the course, send me an email and make sure you include your course number and section number in your email. Any question regarding the Labs should be directed to your Lab TA.

Course Description:

PHYS 122 is the second of a two-semester series in general physics. The course is a continuation of PHYS 121, and covers waves, electricity and magnetism, optics, and modern physics. This survey course, together with PHYS 121, generally satisfies the minimum requirement of medical and dental schools. Below is an overview of the main topics we will discuss in class:

<p>Oscillations and Waves</p> <ul style="list-style-type: none">• Oscillations• Traveling Waves and Sound• Superposition and Standing Waves <p>Electricity and Magnetism</p> <ul style="list-style-type: none">• Charges and Forces• Electric potential• Current and Resistance• Circuits• Magnetic Fields and Forces• EM Induction and EM Waves• AC Electricity	<p>Optics</p> <ul style="list-style-type: none">• Ray Optics• Wave Optics• Optical Instruments <p>Modern Physics</p> <ul style="list-style-type: none">• Quantum Physics• Physics of Atoms
--	---

ESSENTIAL INFORMATION ABOUT THE COURSE

PLEASE READ CAREFULLY!

Lectures

- Lecture videos will be uploaded every week. On average, we will go over one chapter per week, so be sure to keep up with all the lecture videos every week! I highly recommend watching the videos during normal class time.
- The notes will be uploaded with the videos.
- Please note that we cover many topics during the semester, therefore, there is not enough time to work on many example problems in class. Make sure you solve as many problems as possible and ask your TA for help. Problem solving is the only way you can learn these concepts. Always show up in your discussion classes with your questions!
- Note that NOT all materials will be directly covered in lectures. The combination of all activities during Lecture hours, Labs, and discussion sessions will help you learn the concepts. **Remember, you can Not learn physics by reading the**

textbook only. Physics is Problem Solving! You will learn the concepts through practicing and working on problems. I will upload practice problems on ELMS with a key before the exams. The complete solution to practice problems will Not be provided. I usually discuss some of them in class or upload separate videos on the practice problem sets. We have created a **Piazza** board for this course where you can post your questions and our TAs can help you.

- Laboratory work will be carried out with the assistance of the **Expert TA** software, whose website is (<https://theexpertta.com/>). This website is how you will access your lab manual, lab videos, data, and additional assignments. You can purchase the access directly from the Expert TA website. The table below displays the class codes that you will use to purchase access to your section of the lab. In order to purchase your code, you should visit

<https://login.theexpertta.com/registration/classregistration.aspx>

at which point you will be prompted to enter a class code. When you enter your class code, you will be prompted to register and pay. **(If you encountered any errors, try to enter the code manually).**

Section	Class Registration URL
0101	http://goeta.link/USH22MD-AA4531-20Z
0102	http://goeta.link/USH22MD-60B144-20Y
0105	http://goeta.link/USH22MD-EC9E64-20X
0401	http://goeta.link/USH22MD-C2062B-20W
0402	http://goeta.link/USH22MD-E45669-20V
PDS1	http://goeta.link/USH22MD-70B12F-1YU

Labs

- Students are required to complete a total of **10** laboratory assignments.
- Each week you will do the designated laboratory exercise, coordinated by your Teaching Assistant, and complete the assigned experiment.
- You should read the lab description beforehand. **For each lab, you must submit to ELMS complete lab report and answers to the questions BEFORE the due date.**
- **Please check the guidelines and ask your TA as how to prepare your lab report to avoid missing points.**
- **Late lab reports will not be accepted unless there is a valid excuse and it is communicated beforehand.**
- Your lab grade will be based on your lab report.
- The lab session will be held synchronously on Zoom.
- **Lab reports** are due one week after the day the experiment is done.
- Submission of lab reports is through ELMS.

	<ul style="list-style-type: none"> • The format expected for the lab reports is the one given in the TOC and Introduction part of the lab manual. • Pre-lab questions are due before the lab session begins. • Students only need to answer the questions on the ExpertTA website. • Students are not required to submit pre-lab questions for the first experiment.
<h2>Discussions</h2>	<ul style="list-style-type: none"> • Discussion sessions are a great place to clear any confusions about the materials and ask questions about the homework problems. • You will have a quiz during your discussion class (%10 of total grade). • These discussions sessions will be conducted by Teaching Assistants, where problems will be worked with student participation.
<h2>Homework</h2>	<ul style="list-style-type: none"> • Homework will be carried out with the assistance of the Expert TA website. Please notice that Expert TA for Homework is separate from Expert TA for labs and you need to purchase both in order to complete your HW and your lab work. • Homework problems from the textbook will be assigned throughout the term. • The following link will prompt you to the registration website: http://goeta.link/USH22MD-B48A7B-215 • Turning in late homework is not allowed under any circumstances. • It is your responsibility to check the deadline frequently to make sure you do not miss due dates. • Homework will be %20 of your total grade.
<h2>Quiz</h2>	<ul style="list-style-type: none"> • During the discussion session, every week you will be given an open book, open notes quiz based on the topics discussed in class via ELMS quiz section.
<h2>Exams</h2>	<ul style="list-style-type: none"> • There will be three mid-term exams and one final exam. • You will need a regular calculator with standard trigonometry functions. • The exams will be given via the ELMS quiz tool. The LockDown Browser is required for these exams. There is a TestExam assignment under the quiz section. Please take that test assignment to make sure your LockDown Browser is properly installed. • You can have a one-page formula sheet (No Problem Solutions allowed!) with you during the exam and a picture of that should be uploaded with your solutions. • For midterms only one side of the sheet is allowed • For the final exam you can use both sides of the sheet. • Write your name and section on your formula sheets.

- Formula sheet should not have any examples, drawings, interpretation or explanation. These will be considered as cheating. (See the example below)
- **You can label the parameters and formulas.**
- Exams must be taken on the scheduled dates. Unless it is discussed otherwise.
- There will be **NO make-up for Midterms.**
- The lowest of three scores in the midterm exams will be dropped so **if you miss a midterm, that will automatically be your lowest midterm.**
- There will be an extra credit question on each exam.
- For the final exam, make-up exams will be given only under extraordinary circumstances if arrangements are made with the instructor ahead of time.
- **Exams will cover the material discussed in the class, lecture notes, problems solved in class, HW problems, and problems done during the discussion sessions.**
- A problem set will be uploaded before each exam for practice.
- **The following is an example of what is and is not allowed on the formula sheet.**

Electric charges

$$F = k \frac{q_1 q_2}{r^2}$$

Electric force

distance

Allowed on the formula sheet



$q_1 = 5c$ $q_2 = 5c$

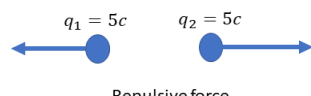

Repulsive force

NOT allowed on the formula sheet



$$\frac{1}{f} = \frac{1}{p} + \frac{1}{q}$$

f focal length
 p object distance
 q image distance

Allowed on the formula sheet

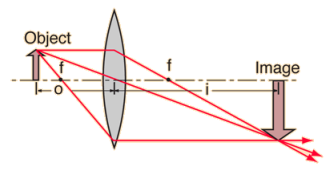
Object

Image

NOT allowed on the formula sheet



Course Grade break-down

- The final grade will be based on the components below.

Homework	% 20
Quiz	% 10
Lab	% 20
Mid-term exams	% 30 (%15 each)
Final exam	% 20

- **Best two out of three midterms will be considered as the midterm grade .**
- **There will be no makeup exams.**
- **Each midterm and the final exam will have multiple choice and comprehensive questions.**
 - You can have a calculator.
 - You will get most credits even if you don't calculate the final number as long as:
 - you reduce the numbers to a simplified ratio and all the powers are reduced to single power.
 - You simplify the units to correct and general units used for the final quantity of interest.
 - The final grade will be set at the end of the semester after all work is completed.
 - The final grade will be determined by the University of Maryland grading policy, quoted below:
 - A excellent mastery of the subject and outstanding scholarship.
 - B good mastery of the subject and good scholarship.
 - C acceptable mastery of the subject and the usual achievement expected.
 - D borderline understanding of the subject. It denotes marginal performance, and it does not represent satisfactory progress toward a degree.

Grading Scheme

A+	100 %	to	98.0%
A	< 98.0	to	95.0%
A-	< 95.0	to	90.0%
B+	< 90.0	to	88.0%
B	< 88.0	to	85.0%
B-	< 85.0 %	to	80.0%
C+	< 80.0 %	to	78.0%
C	<78.0 %	to	75.0%
C-	< 75.0 %	to	70.0%
D+	<70.0 %	to	68.0%

	<p>Please note, there will be NO extra points/activities available beyond the extra credit questions on each exam so plan ahead. If you are struggling with the materials, reach out before it's too late. The last day of classes is NOT a good time to reach out and ask for help!</p>
<p>Tutoring and Help</p>	<ul style="list-style-type: none"> • You have access to various resources including my office hours, your TAs for the course, discussion sessions, and the Piazza platform. • Feel free to help each other on the Piazza board if you see a problem that you know how to solve! Your valuable comments are always helpful! • Your instructor and TA have office hours, both scheduled and by appointment, and are happy to help you outside of class. • We are here to help you learn, so please don't hesitate to reach out and make sure you understand the course materials before it's too late.
<p>Course Evaluation</p>	<ul style="list-style-type: none"> • Your participation in the evaluation of courses through CourseEvalUM is a responsibility you hold as a student member of our academic community. • Your feedback is confidential and important to the improvement of teaching and learning at the University. • You can go to the CourseEvalUM website (https://courseevalum.umd.edu/) to evaluate the course.
<p>Students with disabilities</p>	<p>Students with disabilities should contact the instructor at the beginning of the semester so that appropriate arrangements can be made to accommodate the student's needs. Accommodations will be provided to enable students with documented disabilities to participate fully in the course.</p>
<p>Academic Integrity</p>	<ul style="list-style-type: none"> • You must work by yourself on exams. • You must work on the homework by yourself. • Discussions with other students are strongly encouraged. But you should not just directly copy from anyone. Doing so is not only dishonest but will hurt your ability to do the problems on the exams.

**Course
Related
Policies**

**Know Your Rights
Know the University of Maryland Policies for Undergraduate Students**

For more information please visit this webpage:

<http://www.ugst.umd.edu/courserelatedpolicies.html>

**Discussion
and lab
schedules:**

**Check
Testudo**

Section	Teaching Assistant	email
Discussion 101	Heller, Stefan	stheller@umd.edu
Lab 101	Heller, Stefan	stheller@umd.edu
Discussion 102	Guo, Yuxun	yuxunguo@terpmail.umd.edu
Lab 102	Dr. Heidarian	nheidari@umd.edu
Discussion 105	Sanderson, Joshua	jdsander@terpmail.umd.edu
Lab 105	Sanderson, Joshua	jdsander@terpmail.umd.edu
Discussion 401	Sanderson, Joshua	jdsander@terpmail.umd.edu
Lab 401	Sanderson, Joshua	jdsander@terpmail.umd.edu
Discussion 402	Waxter, Quinn	qwaxter@umd.edu
Lab 402	Waxter, Quinn	qwaxter@umd.edu
Discussion PDS1	Sanderson, Joshua	jdsander@terpmail.umd.edu
Lab PDS1	Sanderson, Joshua	jdsander@terpmail.umd.edu

Lecture/Exam Schedule

The content of the mid-term exams may change depending on how the course develops and based on the need of the students

Week Beginning	Chapters covered during the week
Aug 31	Chapter 14 Oscillations
Sept 7	Chapters 15 Traveling Waves and Sound
Sept 14	Chapters 16 Superposition and Standing Waves
Sept 21	Chapter 20 Electric Fields and Forces
Sept 28	Chapter 20 Electric Fields and Forces
Midterm 1, Wednesday Sept 30th	Chapters 14-15-16-20
Oct 5	Chapter 21 Electric Potential
Oct 12	Chapter 22 Current and Resistance
Oct 19	Chapter 23 Circuits
Oct 26	Chapter 24 Magnetic Fields and Forces
Midterm 2, Wednesday Oct 28th	Chapters 21-22-23-part of 24
Nov 2	Chapter 24 Magnetic Fields and Forces
Nov 9	Chapter 25 EM Induction and EM Waves
Nov 16	Chapter 17 Wave Optics
Nov 23	Chapter 18 Ray Optics
Nov 25-Nov 29 Thanksgiving Break	No Class
Nov 30	Chapter 18 Ray Optics - Chapter 19 Optical Instruments
Midterm 3, Wednesday Dec 2nd	Chapters 24-25-17-18
Dec 7- Last week	Chapter 19 Optical Instruments -Chapter 29 Atomic spectra - Review
Dec 14 Last Day of Classes	Monday-Review
Final Exam – Dec 16-22 (Thursday-Wednesday)	Please check Testudo

Physics 122 Labs, Fall 2020

Monday – Wednesday

Online

Instructor: Dr. Heidarian

nheidari@umd.edu

Wk	Week of	Expt #	Experiment
1	Aug 31	1	The Pendulum
2	Sep 7	--	No Labs This Week (Sep 7 is Labor Day)
3	Sep 14	2	Sound and the Oscilloscope
4	Sep 21	3	Standing Waves on a Vibrating String
5	Sep 28	5	Charge to Mass Ratio of an Electron
6	Oct 5	6	Resistance and Ohm's Law
7	Oct 12	(1 – 6)	Make-Up Week (Expts 1-6 only)
8	Oct 19	9	Polarization of Light
9	Oct 26	7	Diffraction and Interference of Light
10	Nov 2	8	Ray Optics
11	Nov 9	10	Atomic Spectroscopy
12	Nov 16	(7 – 10)	Make-Up Week (Expts 7-10 only)
13	Nov 23	--	Thanksgiving Week – No Labs

14	Nov 30	--	No Labs this Week
15	Dec 7	--	No Labs this Week
16	Dec 14	--	No Labs this Week
16	Dec 14		Last Day of Classes
16	Dec 15		Reading Day
16 - 17	Dec 16 - 22		Final Exams
17	Dec 20		Main Commencement Ceremony